

456/2
MATHEMATICS
Paper 2
2½ hours

Uganda Certificate of Education
MATHEMATICS
Paper 2
2hours 30 minutes

INSTRUCTIONS TO CANDIDATES:

- *Answer all questions in section A and any five questions from section B.*
- *Any additional question(s) answered will not be marked.*
- *All necessary calculations must be done in the same answer booklet/sheets provided, with the rest of the answers. Therefore no paper should be given for rough work.*
- *Graph paper is provided.*
- *Silent non-programmable scientific calculators and mathematical tables with a list of formulae may be used.*

SECTION A (40 MARKS)

1. Simplify $4^{x+1} \times \left(\frac{1}{32}\right)^{2-x} = 16^{\left(x-\frac{1}{2}\right)}$ **(04 marks)**

2. Find the equation of a line passing through the point A(5,4) and is perpendicular to $4x + y = -10$ **(04 marks)**

3. A sales agent gets 10% commission on the first Shs 20.000 worth of goods sold and 15% on all sales above shs 20.000. Find the total sales in shillings of goods sold. If in a certain month he received shs 5.000 as commission payment. **(04 marks)**

4. Evaluate without using mathematical tables or calculator. $\frac{\log_{10} 4 + \log_{10} 9}{\log_{10} 2 + \log_{10} 108}$ **(04 marks)**

5. Two similar can have different heights. One 6cm and the other one 9cm. If the surface area of the larger can is 840 cm². Find the surface area of the smaller can. **(04 marks)**

6. A map has a scale of 1:50.000. On the map is a square piece of land whose area is 16cm². Calculate the actual area of the piece of land in Km². **(04 marks)**

7. Express as a mixed fraction 1.4545 **(04 marks)**

8. Two points A and B have co-ordinates (3, -2) and (6, 1) respectively. A point T divides line AB in the ratio 2:1. Find the position vector of point T. **(04 marks)**

9. Given that $f(x) = 3x+5$ and $g(x) = \frac{2}{x-5}$
Find;
a. $gf(x)$
b. $gf\left(\frac{1}{2}\right)$ **(04 marks)**

10. Two sets M and N are such that $n(M) = 8$ $n(N) = 11$ $n(M \cap N) = 5$ and $n(M \cup N)' = 3$. Find $n(\mathcal{E})$ where \mathcal{E} is the universal set. **(04 marks)**

SECTION B (60 MARKS)

11. Two towns A and B are 300km apart. Two buses X and Y started from A at the same time and travelled towards B. Y travelled at a speed of 10 km/hr faster than X and reached B $1\frac{1}{4}$ earlier than X.

(a) Find the speed of X to 2 s.f. **(8 marks)**

(b) How far from B was X when Y reached B **(4 marks)**

12.

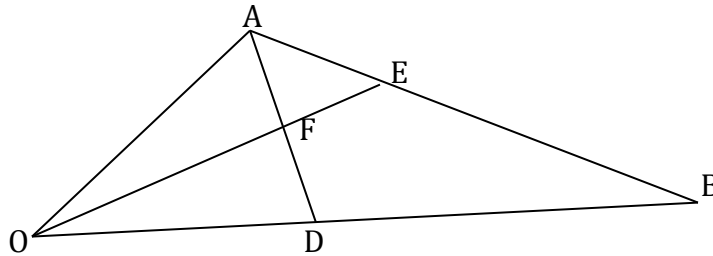

In the figure above E is the midpoint of AB. $OD:DB = 2:3$ and F is the point of intersection of OE and AD.

(a) Given that $\vec{OA} = \mathbf{a}$ and $\vec{OB} = \mathbf{b}$ Express \vec{OE} and \vec{AD} in terms of \mathbf{a} and \mathbf{b} **(2 marks)**

(b) Given further that $AF = t AD$ and $\vec{OF} = h\vec{OE}$, where t and h are scalar. Find the values of t and h. **(6 marks)**

(c) Show that O, F and E are collinear **(4 marks)**

13. Three business partners Wambusa, Aisha and Wekesa contributed Shs 300.000, 500.000 and 700.000 respectively to start a business. They decided that $\frac{1}{3}$ of the profit was to be ploughed back to the business, $\frac{1}{5}$ of the remainder would be kept for emergencies and the rest to be shared in the ratio of their capital contributions. In that year the profit realized was one and a quarter times that of capital. Determine the amount received by each partner that year. **(12 marks)**

14. A bucket is in shape of a frustrum with an open end of diameter 30cm and a bottom diameter of 20cm. the bucket which is 42cm deep is used to fill an empty cylindrical tank of diameter 1.8m and Height 1.2m

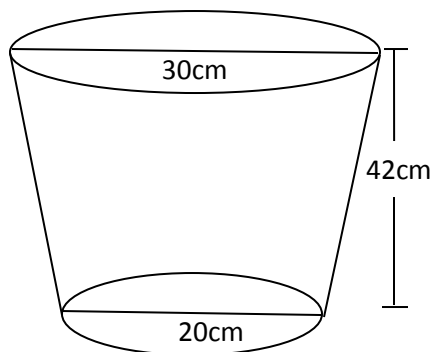

Taking $\pi = 3.142$.

Calculate

- (a) The capacity of the bucket in litres correct to 3dp. **(6 marks)**
- (b) The capacity of the tank in litres correct to 2 dp. **(4 marks)**
- (c) The number of bucket that must be drawn to fill the tank. **(2 marks)**
15. Three hundred and sixty litres of a homogeneous paint is made by mixing three paints **A**, **B** and **C**. The ratio by amount of point **A** to point **B** is 3:2 and that of **B** to **C** is 1:2. Paint **A** costs shs 1800 per litre paint **B** costs shs 2400 per litre and paint **C** shs 1,275 per litre
- (a) The amount of each paint in the mixture **(4 marks)**
- (b) The amount of money need to make 1 litre of the mixture **(4 marks)**
- (c) The percentage profit made by selling the mixture at shs 2,210 per litre. **(4 marks)**
16. A school has a teaching staff of 22 teachers 8 of them teach mathematics, 7 teach physics and 4 teach Chemistry. Three teach both mathematics and Physics and one teaches Mathematics and Chemistry. No teacher teaches all the three subjects. The number of teachers who teach Physics and Chemistry is equal to that of those who teach Chemistry but not physics.
- (a) Represent the above information on a Venn diagram.
- (b) Find the number of teachers who teach
- (i) Mathematics only
 - (ii) Physics only
 - (iii) None of the three subjects.

(c) Find the probability that a teacher picked at random teaches only one subject.

(12 marks)

17. (a) Tap P can fill a tank in 2 hours while tap T can fill the same tank in 3hrs. Both taps are turned on for 30 minutes after which tap R is closed. Find how long tap T takes to fill the remaining part of the tank.

(8 marks)

(b) Simplify the expression below leaving your answer in the form $\frac{a}{b} C$

$$\frac{\sqrt{5}}{2\sqrt{5} - \sqrt{5}} + \frac{\sqrt{5}}{2\sqrt{5} + \sqrt{5}}$$

(04 marks)

End -