

P510/2

PHYSICS

Paper 2

July/Aug. 2019

2½ hours

UNASSE

Uganda Advanced Certificate of Education

S.6 MOCK EXAMINATIONS, JULY/AUGUST- 2019

PHYSICS

Paper 2

(Principal Subject)

2 hours 30 minutes

INSTRUCTIONS TO CANDIDATES:

Answer only **five** questions, taking at least **one** question from each of the sections **A, B, C** and **D**, but **not** more than **one** question should be chosen from **either** section **A** or section **B**.

Any additional question(s) answered will **not** be marked.

Mathematical tables and squared paper will be provided.

Non-programmable Silent Scientific Calculators may be used.

Assume where necessary:

Acceleration due to gravity, g = 9.81 m s^{-2}

Speed of light in Vacuum, c = $3.0 \times 10^8 \text{ m s}^{-1}$

Speed of sound in air, v = $3.40 \times 10^2 \text{ m s}^{-1}$

Electronic charge, e = $1.60 \times 10^{-19} \text{ C}$

1 electron volt, 1eV = $1.60 \times 10^{-19} \text{ J}$

Electronic mass, m_e = $9.11 \times 10^{-31} \text{ kg}$

Permeability of free space, μ_0 = $4\pi \times 10^{-7} \text{ H m}^{-1}$

Permittivity of free space, ϵ_0 = $8.85 \times 10^{-12} \text{ F m}^{-1}$

The Constant, $\frac{1}{4\pi\epsilon_0}$ = $9.0 \times 10^9 \text{ F}^{-1} \text{ m}$

SECTION A

1. (a) (i) State the laws of refraction of light. (2 marks)
- (ii) A ray of monochromatic light travels from air through rectangular prisms, made of water and glass respectively and re-emerges into air. If n_a , n_w and n_g are the absolute refractive indices of air, water and glass respectively. Show that $n_a \sin i_a = n_w \sin i_w = n_g \sin i_g$ where i is the angle the ray makes with the normal in a given medium. (4 marks)
- (b) (i) Write down an expression relating apparent displacement, \mathbf{d} , real depth, \mathbf{t} , and refractive index, \mathbf{n} , of a material. (1 mark)
- (ii) A source, \mathbf{S} of monochromatic light is placed very close to slab \mathbf{A} and in front of two parallel glass slabs \mathbf{A} and \mathbf{B} of thicknesses 9.0 cm and 10.0 cm and refractive indices 1.50, and 1.54 respectively separated by a 15 cm thickness of air as shown in figure 1

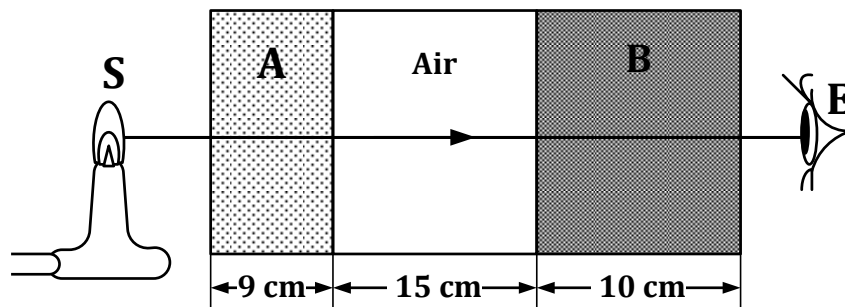

Fig . 1

- How far does the source \mathbf{S} appear to be to an observer \mathbf{E} from the end of the surface of glass \mathbf{B} ? (3 marks)
- (c) (i) Define the terms *critical angle* and *total internal reflection*. (2 marks)
- (ii) A ray of monochromatic light is incident from air onto the plane surface of the core of an optical fibre at an angle \mathbf{i} to the axis of the fibre. The core of the fibre has a refractive index of 1.60 while its cladding has a refractive index of 1.50. Determine the value of \mathbf{i} beyond which the ray just gets propagated into the fibre. (3 marks)
- (d) Describe an experiment to determine the focal length of a convex mirror using a plane mirror. (5 marks)

2. (a) (i) Define *power of lens* and state its *SI unit*. (2 marks)
- (ii) Calculate the combined power of the convex and concave lenses of focal lengths 20cm and 5.0cm respectively placed in contact. (3 marks)
- (b) (i) What is meant by *accommodation* of the eye? (1 mark)
- (ii) A short sighted person has his un-corrected far point of 250cm. Sketch a ray diagram to show how the defect can be corrected and Calculate the focal length of the most appropriate lens to be used to correct the defect. (4 marks)
- (c) (i) Describe the structure and mode of operation of an astronomical telescope in normal adjustment. (5 marks)
- (ii) Derive an expression for the angular magnification of the telescope in (i) above. (3 marks)
- (d) State two advantages of reflecting telescopes over refracting telescopes. (2 marks)

SECTION B

3. (a) (i) What is sound? (2 marks)
- (ii) Explain why the moon is termed to as a "*silent satellite*". (3 marks)
- (b) Describe an experiment to determine the speed of sound in air using a resonance tube and the graphical method. (6 marks)
- (c) The graph below shows the relationship between *length l* of air resonating in a tube open on one end with *periodic time* of a vibrating oscillator placed just above the open end of the tube.

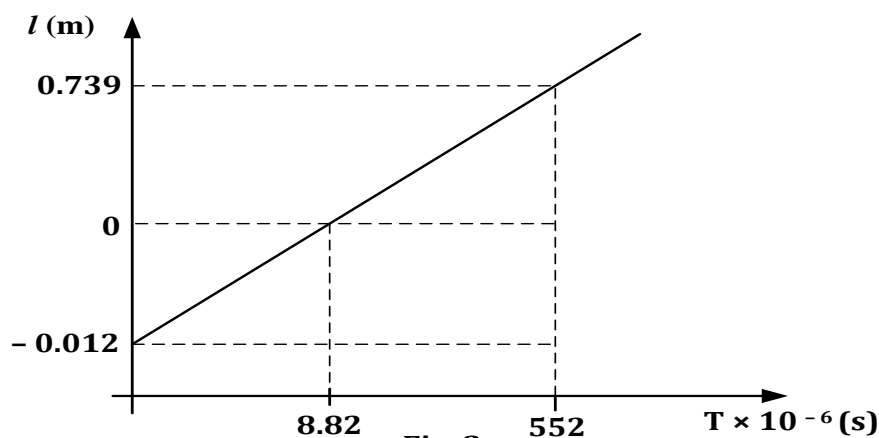

Fig. 2

Use the graph given to determine the;

(i) speed of sound in air. (3 marks)

(ii) the end correction of the tube. (2 marks)

(d) Explain how the speed of sound in air is affected by the;

(i) Temperature of air. (2 marks)

(ii) density of air. (2 marks)

4. (a) What is meant by;

(i) polarized light? (1 mark)

(ii) plane of polarization? (1 mark)

(b) (i) Describe an experiment to produce plane polarized light by reflection. (5 marks)

(ii) Plane polarized light is obtained by reflection when a glass slab of refractive index 1.52 is immersed in a liquid of refractive index 1.10 and is illuminated with a fire beam of un-polarized light.

Determine the polarizing angle corresponding to the two media.

(3 marks)

(c) The figure 3 shows an arrangement for observing interference fringes from two narrow slits. A monochromatic beam of light of wave length 450 nm illuminates slits **A** and **B** that are separated by a distance of 0.30 mm. The screen is 2.0 m from the common plane of the slits.

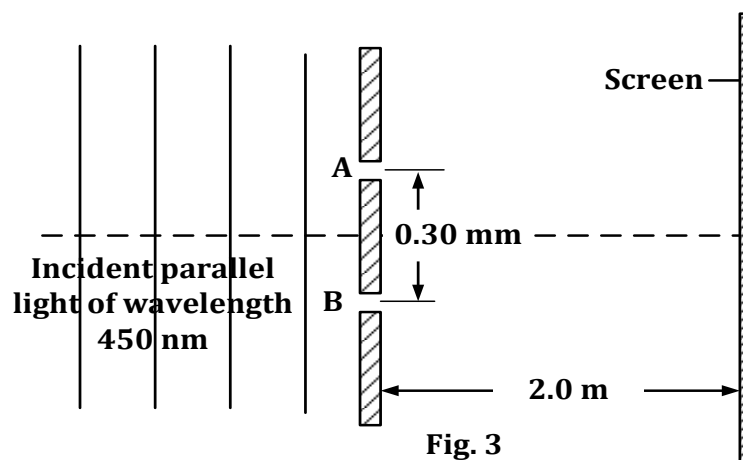

(i) Explain the pattern obtained on the screen. (2 marks)

(ii) Calculate the spacing between the fringes obtained on the screen. (2 marks)

(iii) What would be observed when the separation between slits A and B is increased? (2 marks)

- (d) (i) What is a diffraction grating? (1 mark)
(ii) Light of wave length $6.00 \times 10^{-7}m$ is incident normally on an optical transmission grating of spacing $2.00 \mu m$. Calculate the maximum order of diffraction possible, hence determine the number of diffracted beams obtained. (3 marks)

SECTION C

5. (a) Define the following terms:
- (i) Magnetic meridian. (1 mark)
(ii) Angle of dip. (1 mark)
- (b) Describe an experiment to determine the angle of dip over the earth's surface using a search coil. (6 marks)
- (c) (i) Derive an expression for the initial deflection torque experienced by a freely pivoted rectangular coil of wire of N turns each of area A , carrying a current I having its shorter sides parallel to a uniform magnetic field of flux density B . (4 marks)
- (ii) The figure 4 shows two plane circular coils C_1 and C_2 of 10 turns and 50 turns carrying currents of 2A and 10A respectively with their planes initially making an angle of 15° to each other. If the radii of C_1 and C_2 are 2.5 cm and 7.0 cm respectively.

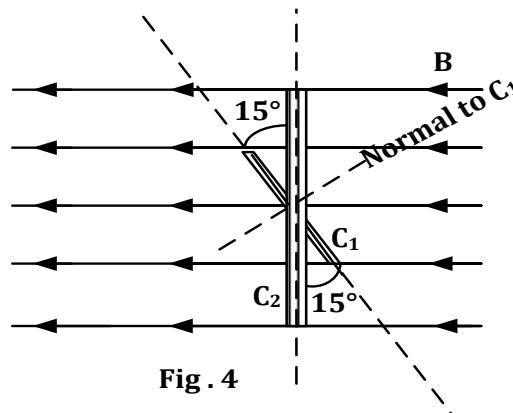

Fig . 4

Determine the torsion constant of the suspension wire of C_1 when it turns through 30° when a current flows through it. (4 marks)

- (d) (i) Explain how the sensitivity of a moving coil galvanometer can be increased. (3 marks)
(ii) Give the role played by radial magnetic field in a moving coil galvanometer. (1 mark)

6. (a) (i) Distinguish between self-induction and mutual induction. (2 marks)
- (ii) The figure 5 shows an iron cored inductor of self-inductance 0.5H connected across an a.c. source, $V = 20 \sin 100\pi t$.

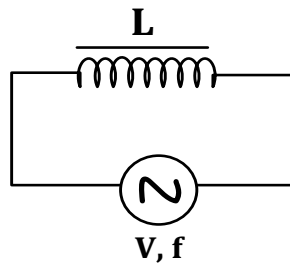

Fig . 5

An Iron rod is inserted in the coil, state and explain what would happen to the iron rod, when an alternating current flows in the circuit.

(3 marks)

- (b) (i) Describe an absolute method of measurement of resistance of a conductor. (5 marks)
- (ii) A metal disc of radius 4.0 cm attached to a rotating system has its plane normal to a uniform magnetic field at the centre of a solenoid of 1000 turns per metre carrying a current of 5.0 A . Determine the resistance of the resistor for which the centre zero galvanometer shows no deflection when the disc is rotated at 3000 revolutions per minute. (3 marks)
- (c) (i) Define the term back E.m.f in an electric motor. (1 mark)
- (ii) Explain the significance of back E.m.f in the motor. (2 marks)
- (d) (i) State any two factors that affect the efficiency of a transformer. (2 marks)
- (ii) Explain how the factors named in (i) above are minimized. (2 marks)

7. (a) Define the terms
- (i) peak voltage. (1 mark)
- (ii) Root mean square value of alternating voltage. (1 mark)
- (b) The circuit in figure 6 shows an electric bulb having a filament of resistance $5\ \Omega$ connected in series with a pure inductor of self-inductance 0.2 H

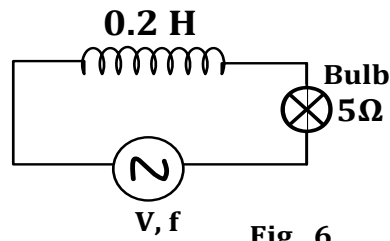

If a current, $I = 68 \sin 100\pi t$ amperes flows in the circuit. Determine the:

- (i) average power rating of the bulb. (3 marks)
 - (ii) Rootmeansquare value of the applied voltage. (3 marks)
 - (iii) The impedance of the circuit. (2 marks)
- (c) (i) What is full wave rectification? (1 mark)
- (ii) With the aid of a circuit diagram explain the smoothing action of a capacitor in full wave rectification process. (4 marks)
- (d) Describe the structure and mode of operation of a repulsion type of moving iron ammeter. (5 marks)

SECTION D

8. (a) (i) What are *equipotential surfaces*? (1 mark)
- (ii) Explain why equipotential lines or surfaces near the conductor are parallel to the surface of the conductor. (3 marks)
- (iii) Why do equipotential surfaces for a point charge get further apart as the distance from the charge increases? (2 marks)
- (b) (i) State Coulomb's law of electrostatics. (1 mark)
- (ii) The figure 7 shows four point charged particles of $+6 \mu\text{C}$, $-3 \mu\text{C}$, $+4 \mu\text{C}$ and $-8.0 \mu\text{C}$ located at points A, B, C and D along the x - axis, with distances $AB = 6\text{cm}$, $BC = 4\text{cm}$ and $CD = 5\text{cm}$.

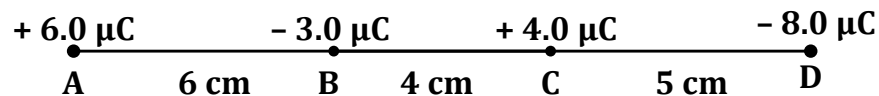
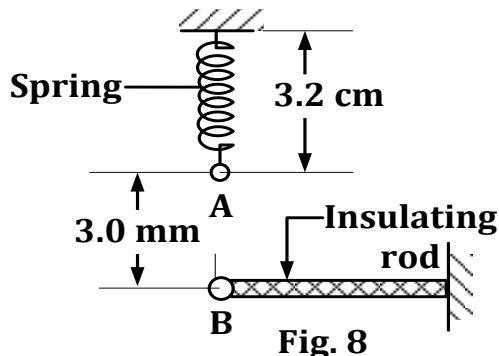

Fig . 7

Determine the acceleration of the $-3 \mu\text{C}$ charged particle having a mass of $1.82 \times 10^{-30} \text{ kg}$. (6 marks)

- (c) (i) The figure 8 shows a tinny metal sphere **A** having a charge of $+ 0.60 \mu\text{C}$ attached to the free end of a spring of length 3.0 cm . When a $- 9.0 \mu\text{C}$ charged particle **B** is placed directly below the sphere, a static equilibrium is established when the sphere is pulled down wards increasing the length of the spring to 3.2 cm when the separation between the charged particles is 3.0 mm .



Determine the force constant of the spring. (4 marks)

- (ii) Give three applications of electrostatics in a modern world. (3 marks)

9. (a) (i) Define the term *dielectric field strength*. (1 mark)

- (ii) A fine electron beam is fired into a region having a uniform magnetic field of 30 mT normal the direction of the beam. An electric field between oppositely charged metal plates separated by 2.0 cm is switched on so that the beam goes undeviated. Determine the maximum potential difference used. (3 marks)

- (b) The figure 9 shows an α - particle (Helium nucleus) whose initial kinetic energy is 6.28 MeV being fired onto a gold nucleus for a head on collision. Given that the atomic number of gold is 79 while that of an α particle is 2 .

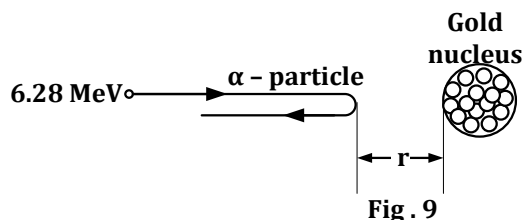

Determine the;

- (i) initial energy of an α - particle in joules. (2 marks)
- (ii) the closest distance of approach of the α - particle to the Gold nucleus. (3 marks)

- (c) (i) Derive an expression for the energy stored in a charged capacitor of capacitance, C , connected across a steady voltage of V volts. (4 marks)
- (ii) The figure 10 shows three identical air capacitors C_1 , C_2 and C_3 each of $2.0 \mu\text{F}$ with C_3 having the space between its plates filled with a dielectric material of dielectric constant 1.5

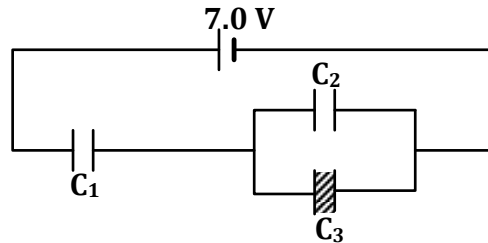

Fig . 10

Determine the total energy stored in the network of capacitors.

(5 marks)

- (d) Describe the energy changes that take place when a capacitor is being charged. (2 marks)

10. (a) (i) Define electrical resistivity of a material. (1 mark)
- (ii) The heating element of an electric toaster consists of a ribbon of Nichrome which is 1.00 mm wide and 0.050 mm thick. What length of ribbon is needed to provide a power of 800 W, when the element is connected to a potential difference of 240 V? (4 marks)

- (b) Describe an experiment to determine electrical resistivity of a metal wire using an ammeter and a voltmeter. (6 marks)
- (c) Explain two advantages as to why a slide wire potentiometer is more accurate than a moving coil voltmeter. (4 marks)
- (d) The figure 11 shows two uniform resistance wires **AB** and **XZ** of lengths 100.0 cm and 120.0 cm respectively connected to a driver cell D of negligible internal resistance. A standard resistor of 4.0Ω is connected in series with wire **AB** of total resistance 5.0Ω . When the contacts **J** and **W** are 40.0 cm from **A** and **y** cm from **Z** respectively, the centre zero galvanometer G shows no deflection.

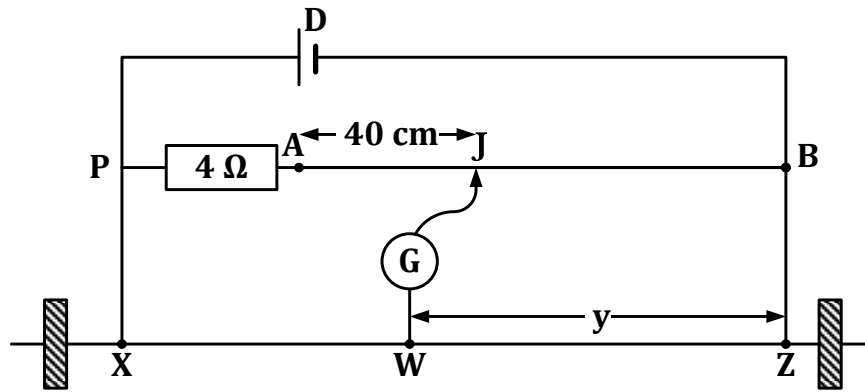

Fig. 11

Determine the value of y .

(5 marks)

= END =